

Dome reference ×××	Trip Force±20(g)		
	130	160	200
Height H±0.03(mm)	0.19	0.21	0.23
Click ratio(%)±15	60		

REVISIONS HISTORY				精度	公差
REV	DESCRIPTION	DATE	MODIFIED BY	CLASS	TOLERANCE
				X.X	±0.30
				X.XX	±0.10
				X.XXX	±0.05
				ANGLES	±0.5°

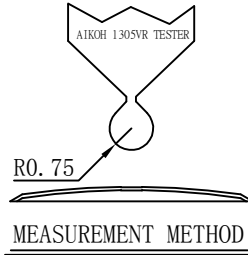
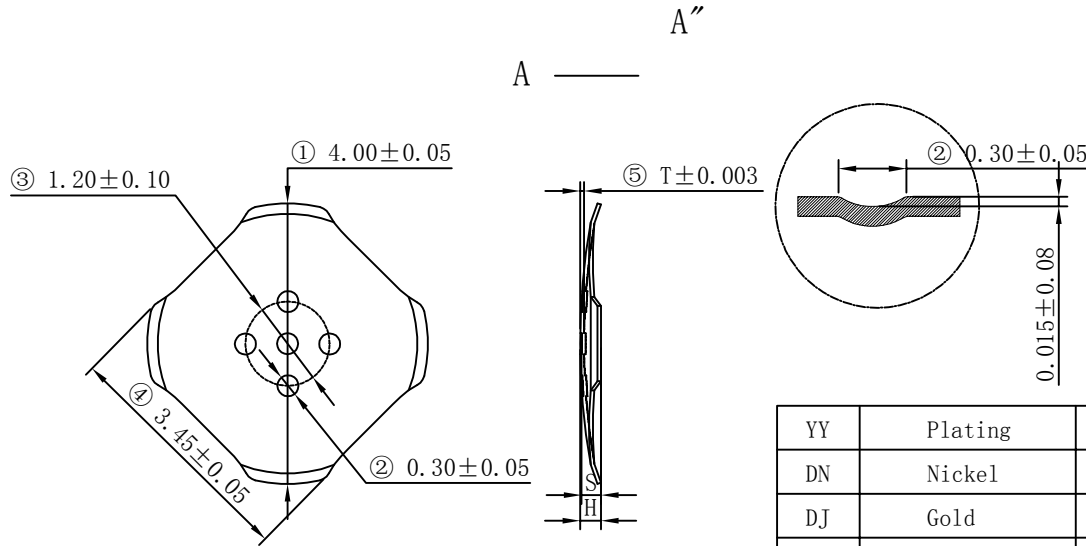

寿命测试规范:  
Specification for life testing  
测试头为直径1.6mm铜质平头, 打击力度为2倍之  
Copper, 1.6mm cylinder flat head, Hit force is 2 times  
弹片标准荷重规格 (超过250gf的弹片规格, 打击力度选择  
standard Froce specification (Over 250gf, Hit force  
500gf), 打击位置为弹片正中心,  
500gf). Right in the center of the Dome.  
打击速度为120次/分, 测试治具底部为平面;  
Speed: 120cycles/min, Height of fixture: 0mm

YY	Plating	Thickness
DN	Nickel	0.2um
DJ	Gold	0.05um
DY	Silver	0.5um

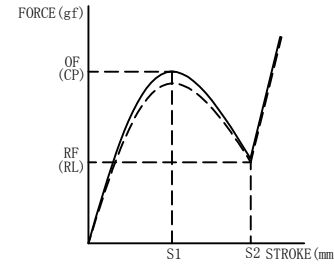

**FORCE CHARACTERISTICS**

OF: OPERATING FORCE (gf)  
CP: COMPRESSION PEAK POINT  
RF: RETURN FORCE (gf)  
RL: RELEASE LOW POINT  
S: STROKE (mm)  
CR: CLICK RATIO  
CR= [(OF-RF)/OFx100%]  
RESISTANCE: ≤1 Ω

麦拉PET+锅仔总高度=产品厚度 .

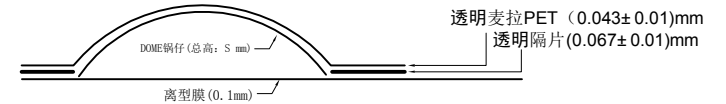

代号说明 Code description	
A	四角 Cross
5D	下凸五点 5 dimples
DN	镀镍 Ni
J	散装包装 Bulk packing

序号 Item	产品型号 Product model	材料厚度 Materials T (mm)	动作荷重 Operating Force (g)	手感率 Click Ratio (%)	弹片高度 Height H (mm)	行程 Travel S (mm)	动作寿命 Operating life (cycles)
1	SD-X4A18-5D-DN-J	0.060	180±20	60±15	0.28±0.03	0.22±0.03	500000

this document is the property of Zigeng. It may not be reproduced without the prior written permission of the owner.

 邦斯达 BONSDA Electronics 深圳市子庚科技有限公司			图号 DWG NO	4A185DDNJ-000	
			三角法 TRIGONOMETRY		
核 准 APPROVED	王瑾雅	材 质 MAT.	SUS301	比例 SCALE	10:1
核 对 CHECKED		产 品 名 称 PRODUCT NAME	金属弹片 METAL DOME	单 位 UNIT	毫 米 MM
制 图 DRAWN	张鸿标	工 作 温 度 OPERATING TEMPERATURE	+105° -40°	版 次 No.REV.	A0
日 期 DATE	2024. 04. 02	储 存 温 度 DEPOSIT TEMPERATURE	+100° -55°	页 码 Page	1/1