

BONSDA
Electronics

Dome reference ×××	Trip Force±20(g)	Trip Force±30(g)	Trip Force±40(g)	Trip Force±50(g)
	300	350	500	
Height H±0.04(mm)	0.45	0.46	0.50	
Click ratio(%)±15	55			

REVISIONS HISTORY				精度	公差
REV	DESCRIPTION	DATE	MODIFIED BY	CLASS	TOLERANCE
				X.X	±0.20
				X.XX	±0.05
				X.XXX	±0.03
				ANGLES	±0.5°

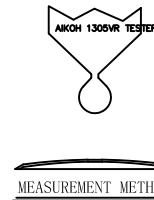
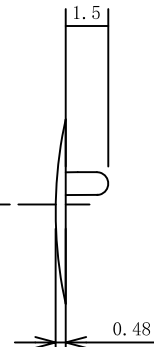
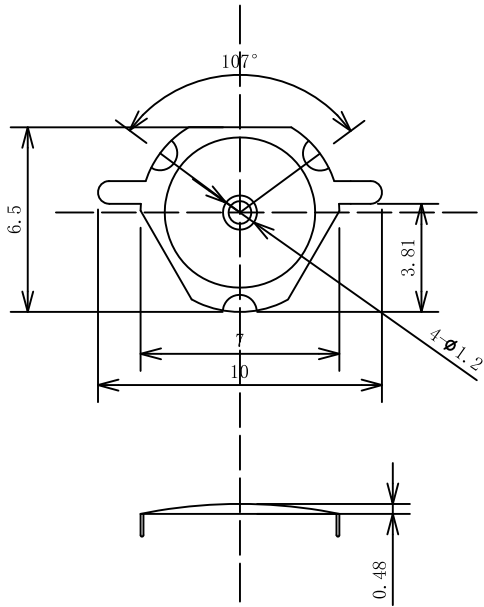

寿命测试规范:
Specification for life testing
测试头为直径1.6mm铜质平头, 打击力度为2倍之
Copper, 1.6mm cylinder flat head, Hit force is 2 times
弹片标准荷重规格 (超过250gf的弹片规格, 打击力度选择
standard Froce specification(Over 250gf, Hit force
500gf), 打击位置为弹片正中心,
500gf). Right in the center of the
打击速度为120次/分, 测试治具底部为平面;
Speed: 120cycles/min, Height of fixture: 0mm

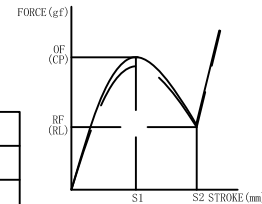

FORCE CHARACTERISTICS
OF: OPERATING FORCE (gf)
CP: COMPRESSION PEAK POINT
RF: RETURN FORCE (gf)
RL: RELEASE LOW POINT
S: STROKE (mm)
CR: CLICK RATIO
CR= [(OF-RF)/OFx100]%
RESISTANCE: ≤100mΩ

YY	Plating	Thickness
DN	Nickel	0.2um
DJ	Gold	0.05um
DY	Silver	0.5um

代号说明 Code description	
A	十字形 Cross
4D	四点型 4 dimples
DJ	镀金 Gild
J	散装包装 Bulk packing

序号 Item	产品型号 Product model	材料厚度 Materials T(mm)	动作荷重 Electing Force (g)	手感率 Click Ratio (%)	弹片高度 Height H(mm)	行程 Travel S(mm)	动作寿命 Operating Life (cycles)
1	SD-M7D40-4D-1.5H-DJ	0.08	400±30	50±20	0.48±0.04	0.36±0.04	10000

This document is the property of Zigeng. It may not be reproduced without the prior written permission of the owner.

邦斯达 **BONSDA** 子庚科技
深圳市子庚科技有限公司

图号: 7D40-4D-1.5H-DJ
TRIGONOMETRY

核准 APPROVED	王瑾雅	材料 MAT.	SUS301	比例 SCALE	1:1
核对 CHECKED		产品名称 PRODUCT NAME	金属弹片 METAL DOME	单位 UNIT	毫米 MM
制图 DRAWN	张鸿标	作温度 OPERATING TEMPERATURE	+105° -40°	版次 No.REV.	A0
日期 DATE	2024.03.18	储存温度 DEPOSIT TEMPERATURE	+100° -55°	页码 Page	1/1

0310002304