

MRK.	DATE	REVISION	SIGN
△			

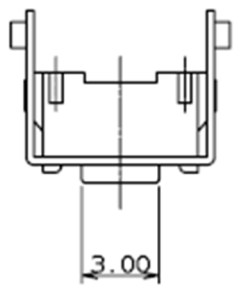

P.C.B DIMENSION

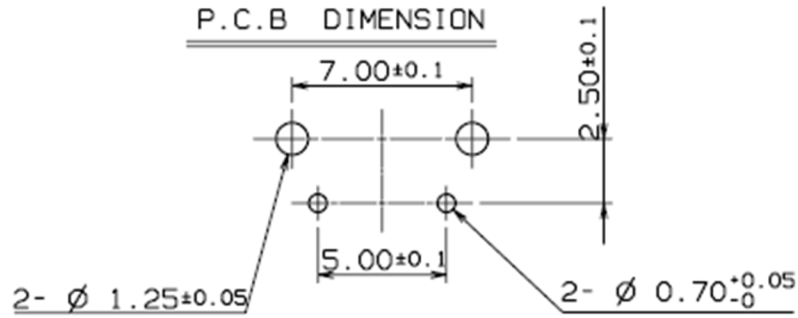

CIRCUIT DIAGRAM

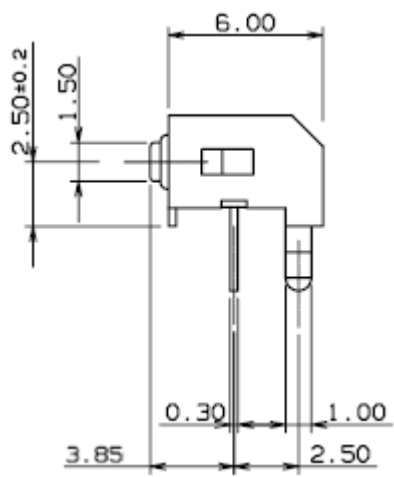
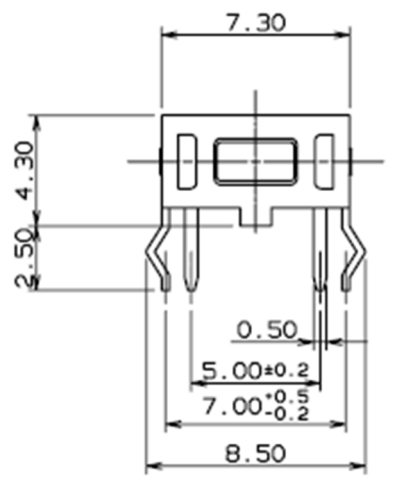

SPECIFICATION

1. RATING : DC 12V 50mA
2. TRAVEL : 0.25 +0.2/-0.1mm
3. CONTACT RESISTANCE : 100mΩ MAX.

4.	MODEL	OPERATING FORCE
	STP-1117	180±50gf
	STP-1117W	250±50gf

01	-				1	-
NO.	DESCRIPTION	MATERIAL	FINISH	Q.TY	VENDOR	
DRAW/DESIGNED	CHECKED	APPROVED	TOL	TITLE	CONTACT SWITCH	
W.J.LEE	J.P.ROH	W.J.LEE	±0.3	MODE	STP-1117X	
			UNIT	SCALE		SHEET
			mm	4:		
邦斯达 BONSUDA				SIZE	DRAW	
SHENZHEN ZIGENG TECHNOLOGY CO., LTD				AA 2	NO.	
					BSD-STP-11170-D-01	1/1

